

BMW CCC, CIC, NBT & EVO Factory Amplified M.O.S.T.® 25 to 12-channel Analog & Digital sound Processor



CCC System



CIC System



NBT System



EVO System

OVERVIEW

The NAV-TV ZEN-25 processor seamlessly converts BMW factory amplified CCC, CIC, NBT and EVO systems to 12 channel analog RCA and single stereo Toslink output. Adding aftermarket amplifiers to the OEM CCC, CIC, NBT & EVO systems has never been so simple. This kit integrates with the OEM M.O.S.T. ® 25 bus to retain volume control, full fade (analog only), balance, treble, bass control & 7 band eq. Note: OEM infotainment systems MUST have a M.O.S.T. 25 factory amplified system for the ZEN-25 to work out of the box. **Vehicles without a factory M.O.S.T. 25 amplifier must be programmed for an OEM amplifier prior to the installation of the ZEN-25. Programming is NOT supported by NAV-TV.**

KIT CONTENTS



ZEN DSP12A-M25
NTV-ASY297



ZEN RCA Output Harness
NTV-HAR315



M.O.S.T. Connector
NTV-CON002



ZEN Power Harness
NTV-HAR316

ZEN -25 Overview

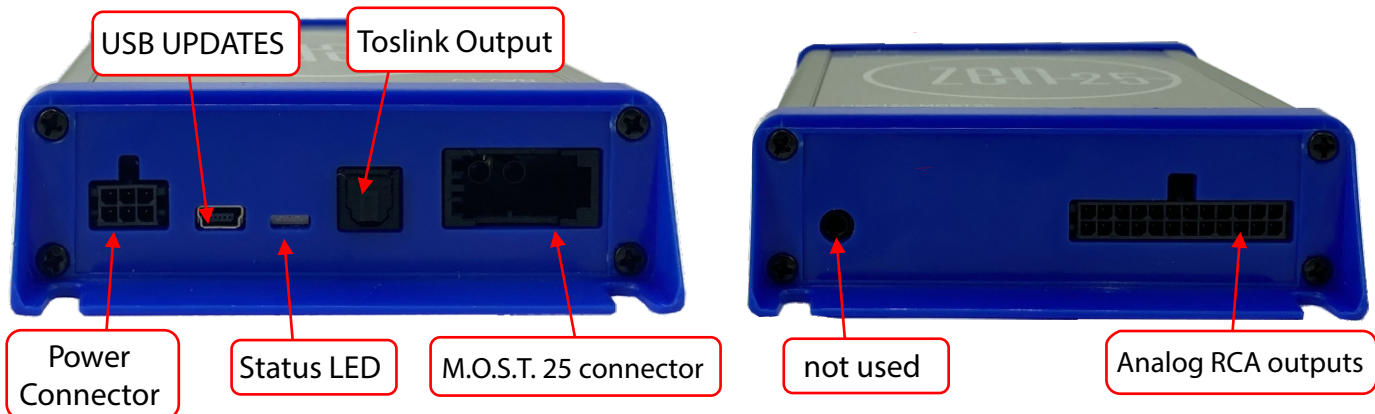

Compatibility chart	YEAR	MAKE	Model
	ANY	BMW	NBT with M.O.S.T. Amplifier
ANY	BMW	CIC with M.O.S.T. Amplifier	
ANY	BMW	CCC with M.O.S.T. Amplifier except 2001-2006 7 series	
ANY	BMW	EVO with M.O.S.T. Amplifier	
ANY	BMW	CCC, CIC, NBT or EVO WO amp requires radio programming prior to installation	

WARNING: Do not connect any RCA cables to the ZEN-25 interface or additional processors prior to properly grounding the aftermarket amplifier(s).

ZEN-25 Installation

Fiber Installation in Vehicles with an Existing M.O.S.T. Amplifier

If the vehicle has a factory M.O.S.T. fiber optic amplifier, it must be removed and the ZEN-25 can be installed in its place. M.O.S.T. BMW amplifiers are located in the left rear section of the trunk.

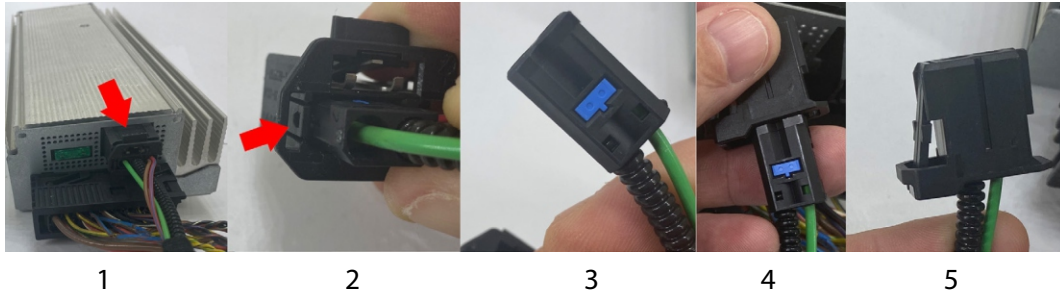

- 1) Locate the factory amplifier, push down on the retaining clip and remove the harness containing the M.O.S.T. connector from the amplifier
- 2) Gently pry the M.O.S.T. retaining clip towards the outside of the factory connector and pull the male fiber optic out of the factory housing. Be careful not to leave grease or debris on the fiber optic cable ends.
- 3) This is what the male fiber optic should look like when removed from the factory harness
- 4) Insert the included M.O.S.T. Connector (NTV-CON002) over the factory male fiber optic end
- 5) This is what the fiber optic cable should look like once completed.

ZEN-25 Power and Output Signal Wiring

- 1) Connect the following wires from the provided power harness:

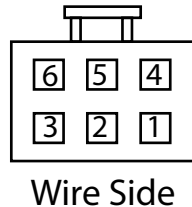

ZEN-25 Pin	Color	To Vehicle
1	Yellow	12V+ Constant
3	Violet	Not Used
4	Black	Ground -
6	Blue	remote out +

This 12v+ remote output wire **MUST** be used for the aftermarket amplifier/DSP remote turn on for proper functionality. If installing more than one Amp/DSP, a relay must be used for reliable system turn on.

- 2) If using analog RCA outputs for signal to the amplifier, connections are made according to the chart below.
WARNING: Do not connect RCA cables to this interface until all amplifiers /DSP are properly grounded. Failure to do this may cause damage to the interface and VOID the warranty!

1	2	3	4	5	6	7	8	9	10	11	12
Left Front	Right Front	Left Front	Right Front	Left Front	Right Front	Left Rear	Right Rear	Left Rear	Right Rear	Center	Sub

- 3) If using Toslink for signal to the amplifier, connect the cable to the Toslink port shown on page 2. NOTE: both analog and digital outputs are aligned to produce sound simultaneously.
- 4) Connect the M.O.S.T. fiber optic cable to the M.O.S.T. 25 connector on the ZEN-25 interface.

System Setup

Before setting gains on the aftermarket amplifiers or DSP, you **MUST** follow the steps below:

1. Set the factory Bass & Treble on all sources to at (0).
2. If the vehicle has a 7 band EQ set it to at (0) as well.
3. Turn the amplifier and DSP input and output gains to zero (all the way down).
4. With dynamic music playing, adjust the radio volume to **MAXIMUM!**
5. Adjust the amplifier and DSP input and output gains to the desired maximum level.

NOTE: From the factory, some vehicle will attenuate audio when in reverse. The ZEN-25 will retain this OEM feature. The same is true for Nav guidance and phone calls.

Multi-Color LED Status Indicator



LED Status	Indicator
Solid Red	M.O.S.T. Active
Violet	M.O.S.T. Trac Commands
Blinking Red	Digital Clipping Indicator
Blinking Blue or Green	USB connected, M.O.S.T. inactive

ZEN-25 System Layout (Analog)

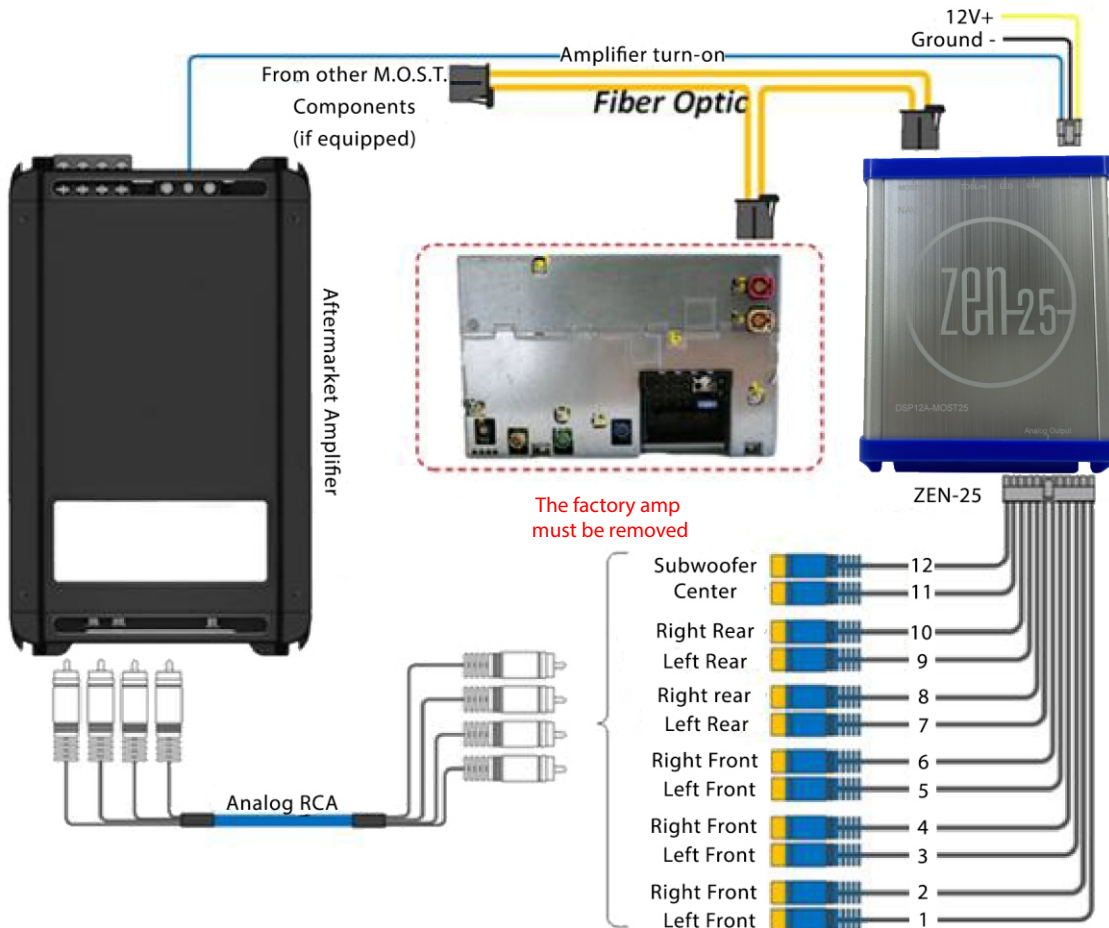

ZEN-25 System Layout (Digital)

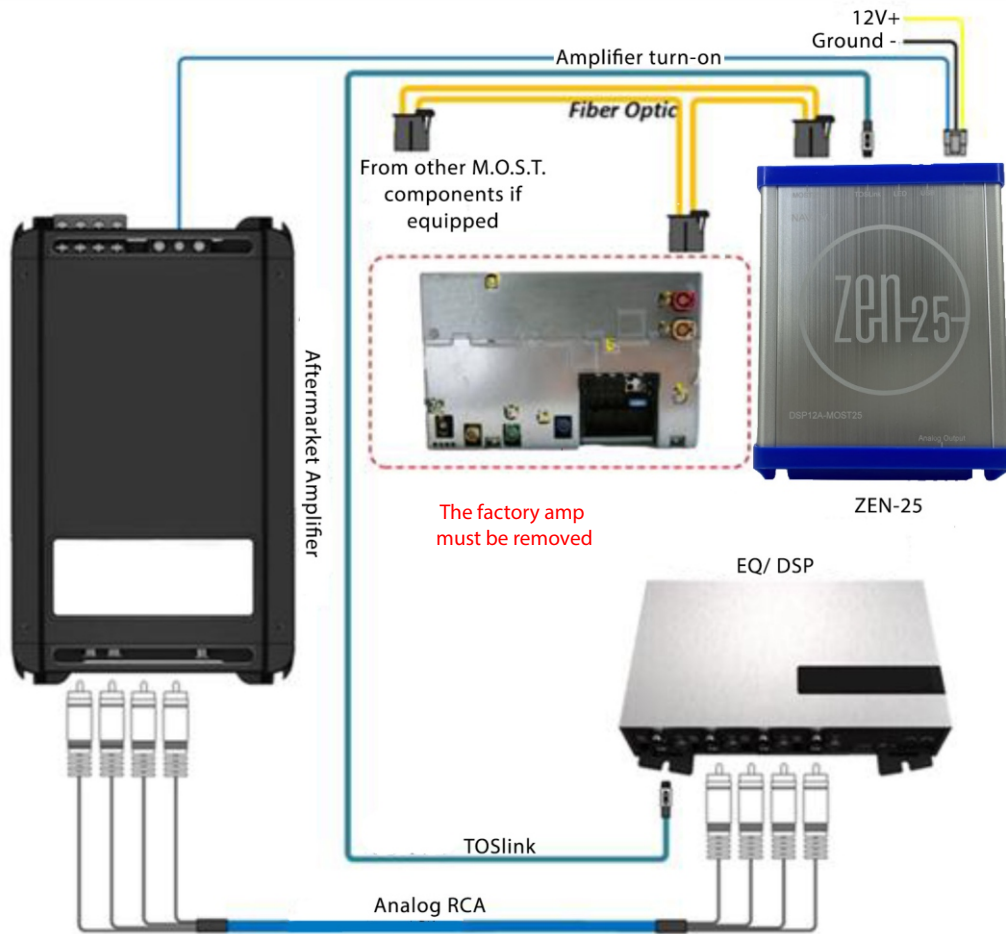

Factory Supported Functions



Bass and Treble Control is retained



Balance is retained. Fade is retained (Analog)



Logic 7 controls the 2 different time alignments



Factory 7 band eq is supported



Factory adjustable PDC and Gong is supported

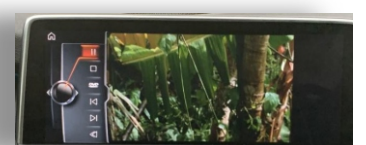

Factory DVD playback in 5.1 or mixdown stereo is supported

In systems with more than one Logic 7 option, 0 is preset 1 and everything else is preset 2.

ZEN Setup

To access the ZEN online configuration tool, first connect the provided USB cable from the ZEN module to the computer. Turn your radio on, open a browser and navigate to zen/ if using a PC or zen.local/ if using a MAC. Wait for the configuration page to load, then adjust settings as required for the installation. **NOTE: All changes will be audible immediately. Make sure to save changes before exiting or unplugging the ZEN interface.**

PC:

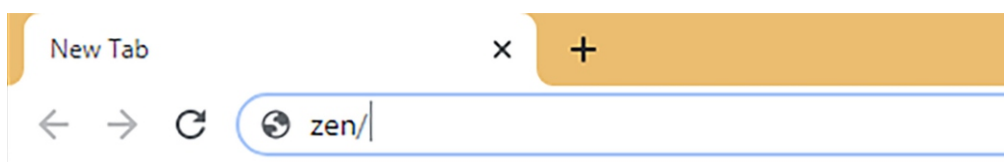

MAC:

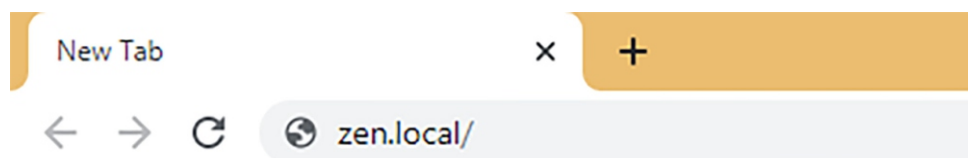

ZEN Setup Page



Vol 13 | L7 Off | SN 205381 | Rev 1.2.17

GLOBAL

Level
-0dBFS

Loudness
Loudness: Off

DownMix
DownMix: Off

Sub control
Bass controls: sub

Delay Units
in

Voice Gain

DIGITAL OUTPUT

Gong Level

Fading
Non-Fading

RESET

SAVE

SPEAKER CONFIGURATION

Full Range Front			Logic7 Off : Delay	180°	Logic7 On : Delay	180°	Strip Audio	Gong Mix	Voice Mix
Output 1	●	Front Left	0 in	<input type="checkbox"/>	0 in	<input type="checkbox"/>	<input type="checkbox"/>	<input checked="" type="checkbox"/>	<input checked="" type="checkbox"/>
Output 2	●	Front Right	0 in	<input type="checkbox"/>	0 in	<input type="checkbox"/>	<input type="checkbox"/>	<input checked="" type="checkbox"/>	<input checked="" type="checkbox"/>
Output 3	●	Front Left	0 in	<input type="checkbox"/>	0 in	<input type="checkbox"/>	<input type="checkbox"/>	<input checked="" type="checkbox"/>	<input checked="" type="checkbox"/>
Output 4	●	Front Right	0 in	<input type="checkbox"/>	0 in	<input type="checkbox"/>	<input type="checkbox"/>	<input checked="" type="checkbox"/>	<input checked="" type="checkbox"/>
Output 5	●	Front Left	0 in	<input type="checkbox"/>	0 in	<input type="checkbox"/>	<input type="checkbox"/>	<input checked="" type="checkbox"/>	<input checked="" type="checkbox"/>
Output 6	●	Front Right	0 in	<input type="checkbox"/>	0 in	<input type="checkbox"/>	<input type="checkbox"/>	<input checked="" type="checkbox"/>	<input checked="" type="checkbox"/>
Full Range Rear			Logic7 Off : Delay	180°	Logic7 On : Delay	180°	Strip Audio	Gong Mix	Voice Mix
Output 7	●	Rear Left	0 in	<input type="checkbox"/>	0 in	<input type="checkbox"/>	<input type="checkbox"/>	<input checked="" type="checkbox"/>	<input type="checkbox"/>
Output 8	●	Rear Right	0 in	<input type="checkbox"/>	0 in	<input type="checkbox"/>	<input type="checkbox"/>	<input checked="" type="checkbox"/>	<input type="checkbox"/>
Output 9	●	Rear Left	0 in	<input type="checkbox"/>	0 in	<input type="checkbox"/>	<input type="checkbox"/>	<input checked="" type="checkbox"/>	<input type="checkbox"/>
Output 10	●	Rear Right	0 in	<input type="checkbox"/>	0 in	<input type="checkbox"/>	<input type="checkbox"/>	<input checked="" type="checkbox"/>	<input type="checkbox"/>
Center and Subwoofer			Logic7 Off : Delay	180°	Logic7 On : Delay	180°	Strip Audio	Gong Mix	Voice Mix
Output 11	●	Front Center	0 in	<input type="checkbox"/>	0 in	<input type="checkbox"/>	<input type="checkbox"/>	<input checked="" type="checkbox"/>	<input checked="" type="checkbox"/>
Output 12	●	Subwoofer	0 in	<input type="checkbox"/>	10 in	<input type="checkbox"/>			

ZEN Global Output Conguration

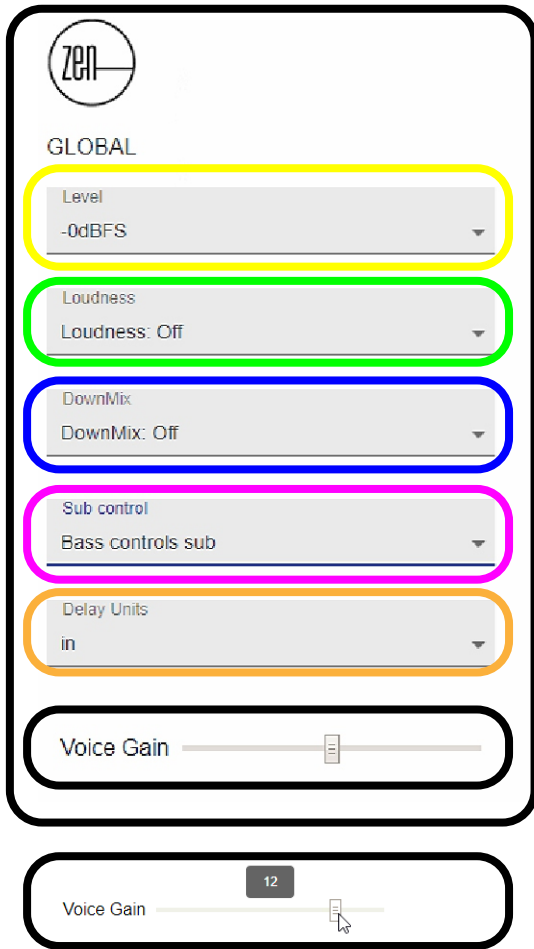

Voice gain allows you to increase or decrease the phone volume settings globally.

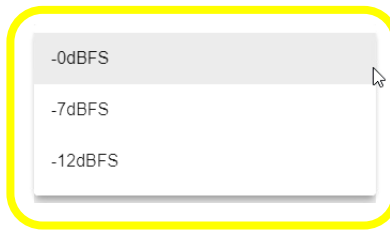

Global output adjustments: At -0dBFS the unit provide a full-scale output. At full volume, minor adjustments of the factory bass or treble can produce digital clipping. With the bass and treble set to neutral the unit will not clip at full volume. -7dB provides the ability to adjust the factory tone controls moderately without clipping at full volume and -12dB allows for maximum adjustment of the OEM controls without clipping.



Selecting "loudness on" will boost low & high frequency response at low volume. The curve will be active until half volume where it will be completely at

A thorough explanation of the functionality of the downmix settings is contained on the next page.

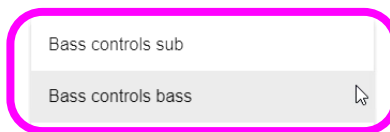

"Bass controls sub" changes the functionality of the factory bass control and creates a subwoofer level controller using the analog sub output. "Bass controls Bass" allows the factory bass control to aect all speakers in the system.

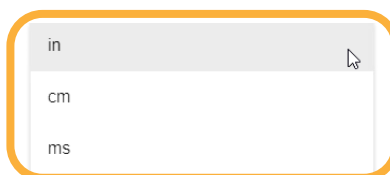

Changes the two adjustable time alignment settings to be measured in inches, centimeters or milliseconds.

ZEN Downmix

Downmix affects the following:

ON:

- 1) Toslink output will downmix 5.1 (DVD etc) channels down to 2 channels.
- 2) Analog Center channel is active on all sources and will output a proper mix or dedicated center channel on DTS or Dolby sources.
- 3) All other Analog Channels are active on all audio sources and are derived for the Left/Right channels or from the dedicated 5.1 channels when applicable.

OFF:

- 1) Toslink output will NOT downmix 5.1 (DVD etc) channels down to 2 channels, only LF/RF channels are streamed.
- 2) Analog Center channel is active ONLY when a 5.1 (e.g. DVD) source is playing. The Center channel WILL NOT PLAY normal, 2-channel stereo sources.
- 3) All other Analog Channels are active on all sources and are derived from the Left/Right channels or from the dedicated 5.1 channels when applicable.

Regardless of the downmix setting, the analog center channel output will always be active during a phone call or when a 5.1 source, like a DVD, is being played. If a center channel speaker is NOT installed in the aftermarket installation, phone calls will come from the left and right front speaker only, instead of the left, right and center. **However, if a center channel speaker is not installed, you MUST USE the Downmix ON setting to be able to hear vocals on 5.1 encoded sources.**

ZEN Downmix Scenario Examples

Source Signal	Downmix	Toslink Output	Analog Front	Analog Rear	Analog Center	Analog Sub
2 Channel (music)	ON	STEREO	STEREO FRONT	STEREO REAR	ON	MONO (L+R)
2 Channel (music)	OFF	STEREO	STEREO FRONT	STEREO REAR	OFF	MONO (L+R)
5.1 Surround	ON	DOWNMIXED STEREO	CENTER MIXED INTO FRONT	REAR SURROUND	ON	LFE
5.1 Surround	OFF	STEREO	STEREO FRONT	STEREO REAR	ON	LFE

Mixed Stereo: (Left = Left Front + Center + Left Surround + LFE), (Right = Right Front + Center + Right Surround + LFE)
 LFE: Low Frequency Effects: Surround Subwoofer output

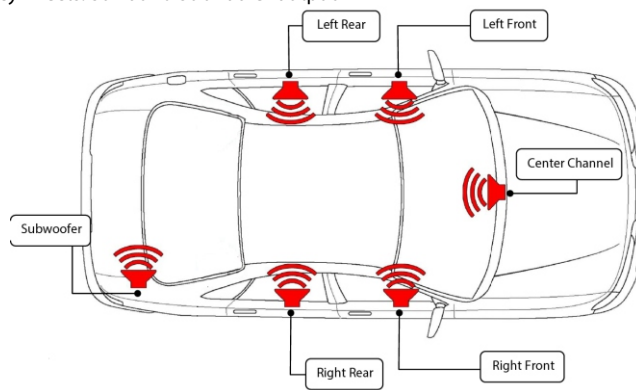

ZEN Digital Output Conguration

Vol 13 | L7 Off | SN 205381 | Rev 1.2.17

SPEAKER CONFIGURATION						
Full Range Front			Logic7 Off : Delay	180°	Logic7 On : Delay	180°
Output 1	●	Front Left	0 in	<input type="checkbox"/>	0 in	<input type="checkbox"/>
Output 2	●	Front Right	0 in	<input type="checkbox"/>	0 in	<input type="checkbox"/>
Output 3	●	Front Left	0 in	<input type="checkbox"/>	0 in	<input type="checkbox"/>
Output 4	●	Front Right	0 in	<input type="checkbox"/>	0 in	<input type="checkbox"/>
Output 5	●	Front Left	0 in	<input type="checkbox"/>	0 in	<input type="checkbox"/>
Output 6	●	Front Right	0 in	<input type="checkbox"/>	0 in	<input type="checkbox"/>
Full Range Rear			Logic7 Off : Delay	180°	Logic7 On : Delay	180°
Output 7	●	Rear Left	0 in	<input type="checkbox"/>	0 in	<input type="checkbox"/>
Output 8	●	Rear Right	0 in	<input type="checkbox"/>	0 in	<input type="checkbox"/>
Output 9	●	Rear Left	0 in	<input type="checkbox"/>	0 in	<input type="checkbox"/>
Output 10	●	Rear Right	0 in	<input type="checkbox"/>	0 in	<input type="checkbox"/>
Center and Subwoofer			Logic7 Off : Delay	180°	Logic7 On : Delay	180°
Output 11	●	Front Center	0 in	<input type="checkbox"/>	0 in	<input type="checkbox"/>
Output 12	●	Subwoofer	0 in	<input type="checkbox"/>	10 in	<input type="checkbox"/>

Time alignment 2 is activated when the factory Logic 7 system is on or highlighted. This allows the user to select a time alignment set to an alternative position in the vehicle. The set up is exactly the same as time alignment one, just measured from a different position in the vehicle. If no time alignment is desired, leave each setting at zero.

Note: If using an external DSP DO NOT use both the ZEN time alignment setting and the time alignment setting of the DSP. Use one or the other.

Vol 00 | L7 Off | SN 205386 | Rev 1.2.18

SPEAKER CONFIGURATION						
Full Range Front			Logic7 Off : Delay	180°	Logic7 On : Delay	180°
Output 1	●	Front Left	0.05 ms	<input type="checkbox"/>	0 ms	<input checked="" type="checkbox"/>
Output 2	●	Front Right	0 ms	<input checked="" type="checkbox"/>	0 ms	<input checked="" type="checkbox"/>
Output 3	●	Front Left	0 ms	<input checked="" type="checkbox"/>	0 ms	<input checked="" type="checkbox"/>
Output 4	●	Front Right	0 ms	<input checked="" type="checkbox"/>	0 ms	<input checked="" type="checkbox"/>
Output 5	●	Front Left	0 ms	<input checked="" type="checkbox"/>	0 ms	<input checked="" type="checkbox"/>
Output 6	●	Front Right	0 ms	<input checked="" type="checkbox"/>	0 ms	<input checked="" type="checkbox"/>
Full Range Rear			Logic7 Off : Delay	180°	Logic7 On : Delay	180°
Output 7	●	Rear Left	0 ms	<input checked="" type="checkbox"/>	0 ms	<input checked="" type="checkbox"/>
Output 8	●	Rear Right	0 ms	<input checked="" type="checkbox"/>	0 ms	<input checked="" type="checkbox"/>
Output 9	●	Rear Left	0 ms	<input checked="" type="checkbox"/>	0 ms	<input checked="" type="checkbox"/>
Output 10	●	Rear Right	0 ms	<input checked="" type="checkbox"/>	0 ms	<input checked="" type="checkbox"/>
Center and Subwoofer			Logic7 Off : Delay	180°	Logic7 On : Delay	180°
Output 11	●	Front Center	0 ms	<input checked="" type="checkbox"/>	0 ms	<input checked="" type="checkbox"/>
Output 12	●	Subwoofer	0 ms	<input checked="" type="checkbox"/>	0 ms	<input checked="" type="checkbox"/>

Each time alignment setting allows the user to invert the phase of each channel by 180 degrees. To invert the phase of each channel, click and highlight the box to the right of the desired channel's time alignment setting. In the example to the left, all channels except channel one are 180 degrees out of phase.

This feature is useful in case of wiring errors where one channel may have been wired out of phase, or in situations where signal cancellation exists due to the individual speaker's location or the physical characteristics of the vehicle interior.

Each time alignment setting has its own phase selection and will not automatically carry over from one time alignment selection to the other.

ZEN Digital Output Conguration

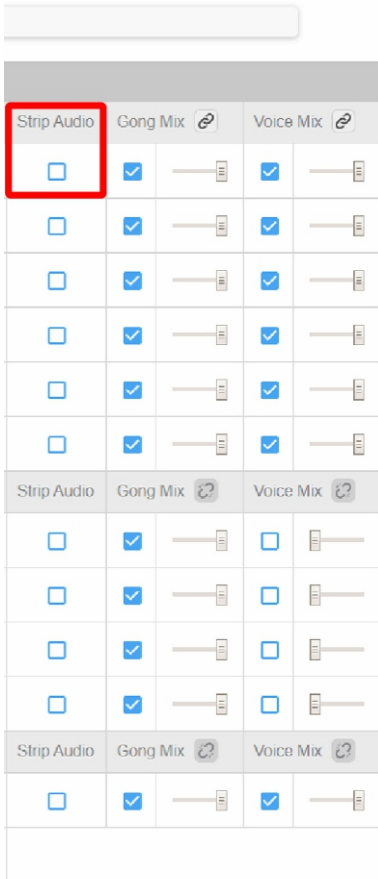

The strip audio feature allows you to remove all audio from each analog output while leaving all factory gongs, handsfree audio and audible navigation prompts. This feature is used commonly with an external DSP that allows digital Toslink and analog inputs to mix. An example would be using the Toslink set to “front fading” to provide audio to the front speakers and using the analog front channels to provide the mix in of the factory gongs, handsfree and audible navigation prompts.

To remove audio from each individual analog channel, select and highlight the strip audio box in the desired channels row. All channels where you wish to remove audio must be checked.

Note: If using both digital and analog inputs to your DSP, where you wish to use the analog channel only for gongs and voice, set the gong setting on the digital output to minimum.

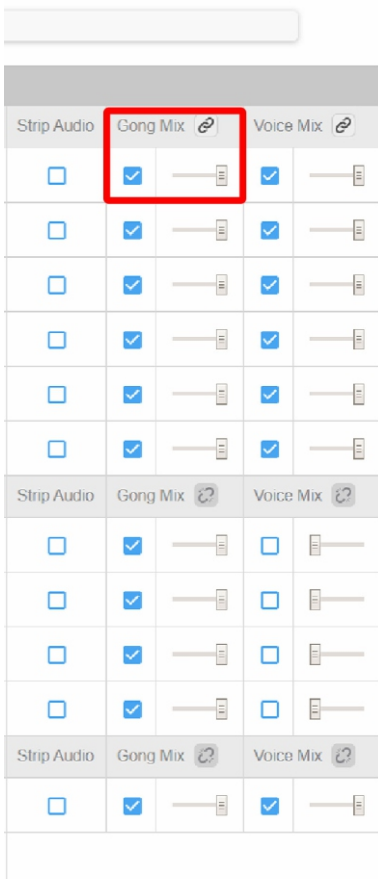

The “gong” setting is to control the volume of the audible gongs and to reassign where the factory gongs are heard. To add the gong to the desired channel, highlight the gong mix select icon. In the example to the left, all channels have been selected to play the factory warning gongs. After selecting the desired channel(s) the volume control slider allows you to control the mix in level of the warning gongs. This allows full control of the alerts and is independant of the audio stream. An example of a factory gong alert is the audible low fuel indicator or bulb malfunction warning.

To raise or lower all channels at once that have been selected for gong mix, click on the gong mix link icon. Please note that the link channel will only allow simultaneous changes to all channels that have been selected for gong mix. All channels that are not selected for gong mix will not raise or lower using the gong link icon.

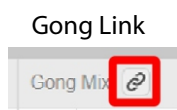

ZEN Digital Output Conguration

Strip Audio	Gong Mix	Voice Mix
<input type="checkbox"/>	<input checked="" type="checkbox"/>	<input checked="" type="checkbox"/>
<input type="checkbox"/>	<input checked="" type="checkbox"/>	<input checked="" type="checkbox"/>
<input type="checkbox"/>	<input checked="" type="checkbox"/>	<input checked="" type="checkbox"/>
<input type="checkbox"/>	<input checked="" type="checkbox"/>	<input checked="" type="checkbox"/>
<input type="checkbox"/>	<input checked="" type="checkbox"/>	<input checked="" type="checkbox"/>
<input type="checkbox"/>	<input checked="" type="checkbox"/>	<input checked="" type="checkbox"/>
Strip Audio	Gong Mix	Voice Mix
<input type="checkbox"/>	<input checked="" type="checkbox"/>	<input type="checkbox"/>
<input type="checkbox"/>	<input checked="" type="checkbox"/>	<input type="checkbox"/>
<input type="checkbox"/>	<input checked="" type="checkbox"/>	<input type="checkbox"/>
<input type="checkbox"/>	<input checked="" type="checkbox"/>	<input type="checkbox"/>
Strip Audio	Gong Mix	Voice Mix
<input type="checkbox"/>	<input checked="" type="checkbox"/>	<input checked="" type="checkbox"/>

The “voice” setting is to control the volume of voice prompts and to reassign where the factory voice prompts are heard. To add voice prompts to the desired channel, highlight the voice mix select icon. In the example to the left, only the front channels have been selected to play voice prompts. After selecting the desired channel(s) the volume control slider allows you to control the mix in level of all voice prompts. This allows full control of all voice prompts and is independant of the audio stream. An example of a voice prompt is audible navigation turn-by-turn instructions or a handsfree phone call.

To raise or lower all channels at once that have been selected for voice mix, click on the voice mix link icon. Please note that the link channel will only allow simultaneous changes to all channels that have been selected for voice mix. All channels that are not selected for voice mix will not raise or lower using the voice link icon.

Voice mix link

Voice Mix
<input checked="" type="checkbox"/>

RESET

SAVE

To complete the set up click “SAVE”. Please note that if you do not save your work all settings will be lost.

RESET

SAVE

To reset the ZEN interface to factory default setting, click “RESET”. A pop up will appear asking if you would like te reset. If an error has been made you may cacel at that point. However, if you accept the pop up the unit will reset to default settings.

ZEN Firmware Update Process

The rmware update process is done online at www.navtv.com. **The unit must have constant power and ground connected on the power harness.** Using the included USB cable, connect the USB to the ZEN interface and your computer. Navigate to www.navtv.com and then select “device updatrer”.

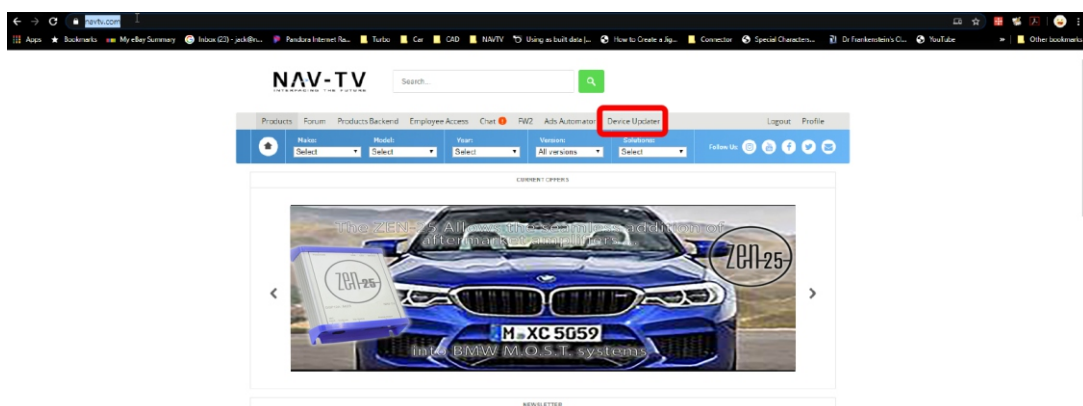

ZEN Firmware Update Process

Once “device updater” has been selected, the website will begin negotiating with the ZEN interface. Be patient, this process may take up to a minute.

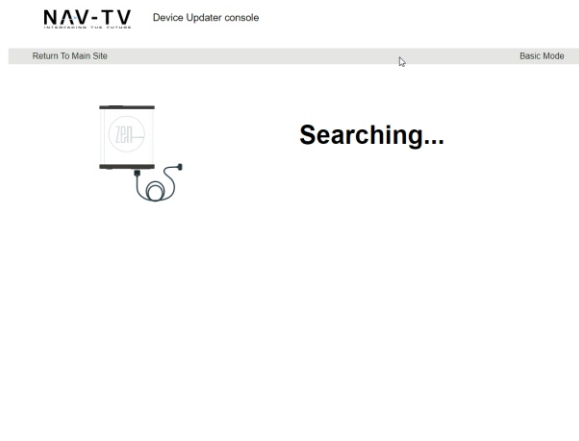

Once the website has linked with the Zen interface it will show you the current firmware in the unit and if a firmware update is available.

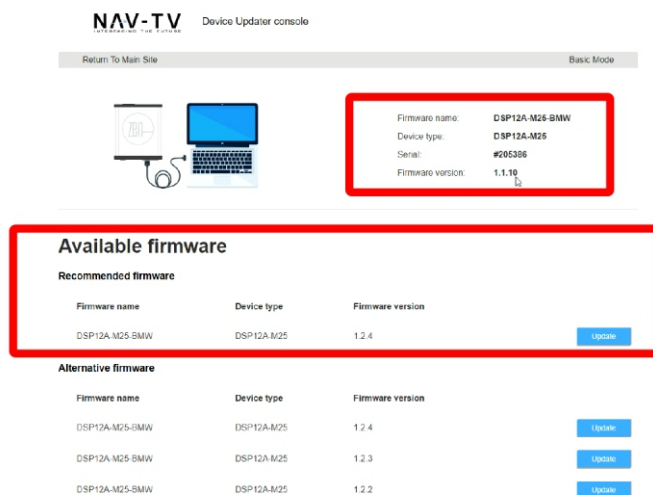

To update to the newest firmware version, click “update”.

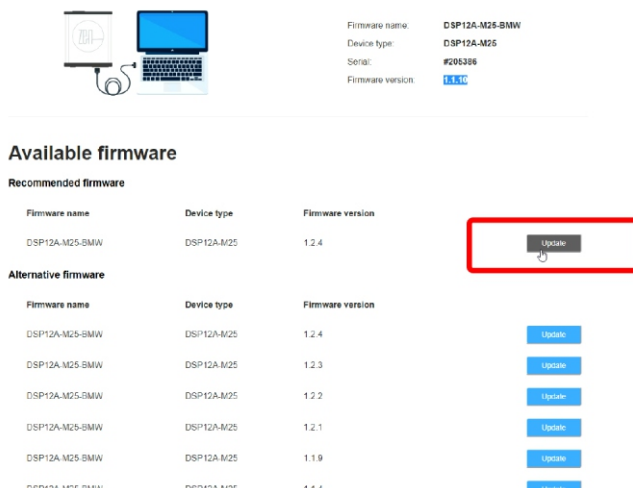

ZEN Firmware Update Process

The device will begin to update. Do not unplug the unit or interrupt the update process. If the unit is unplugged or the update is interrupted repeat the previous step.

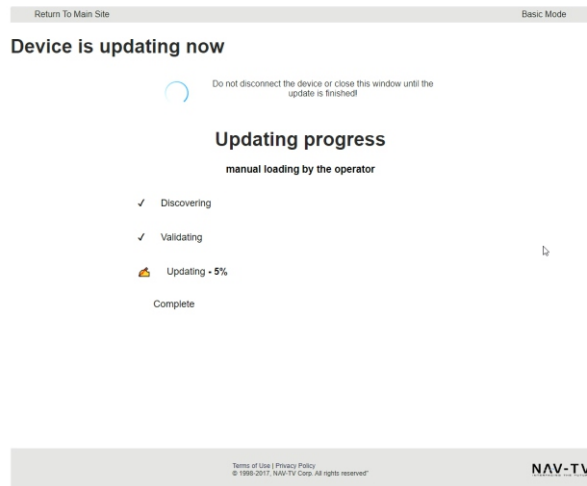

Return To Main Site Basic Mode

Device is updating now

Do not disconnect the device or close this window until the update is finished!

Updating progress
manual loading by the operator

- ✓ Discovering
- ✓ Validating
- 🔥 Updating - 5%
- Complete

Terms of Use | Privacy Policy
© 1998-2017, NAV-TV Corp. All rights reserved! NAV-TV

Once the update process is completed the screen will go to "searching" momentarily. Keep the device plugged in.

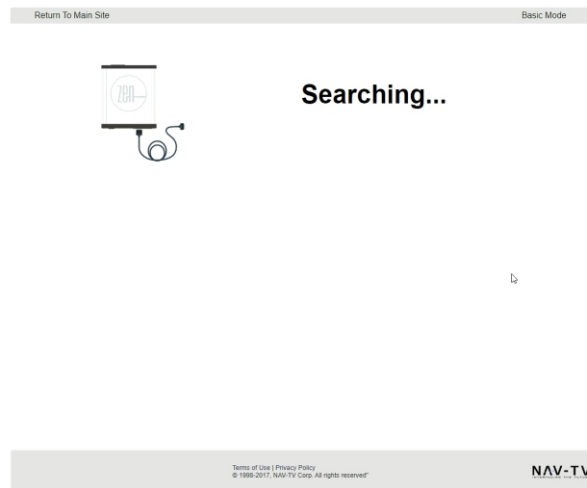

Return To Main Site Basic Mode

Searching...

Terms of Use | Privacy Policy
© 1998-2017, NAV-TV Corp. All rights reserved! NAV-TV

Once the update process is complete it will display the firmware update screen showing you that the unit is up to date.

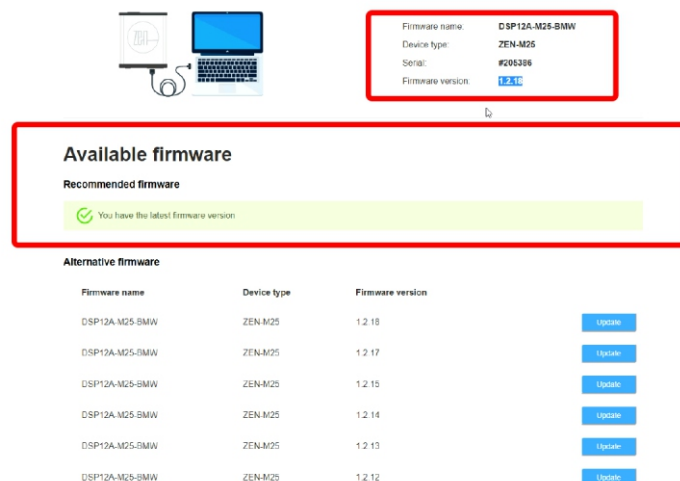

Terms of Use | Privacy Policy
© 1998-2017, NAV-TV Corp. All rights reserved! NAV-TV

Firmware name: DSP12A-M2S-BMW
Device type: ZEN-M2S
Serial: #205386
Firmware version: 1.2.18

Available firmware

Recommended firmware

✓ You have the latest! Firmware version

Alternative firmware

Firmware name	Device type	Firmware version	Update
DSP12A-M2S-BMW	ZEN-M2S	1.2.18	Update
DSP12A-M2S-BMW	ZEN-M2S	1.2.17	Update
DSP12A-M2S-BMW	ZEN-M2S	1.2.15	Update
DSP12A-M2S-BMW	ZEN-M2S	1.2.14	Update
DSP12A-M2S-BMW	ZEN-M2S	1.2.13	Update
DSP12A-M2S-BMW	ZEN-M2S	1.2.12	Update

ZEN Frequently Asked Questions

- 1) PRIOR TO INSTALLATION, verify that the grounding point for your equipment does not have equal to or more than 1 ohm between the grounding point and the battery negative terminal. NAV-TV recommends that the ZEN shares ground and power with the rest of the aftermarket components.
- 2) If you are having any audio bleed over, handfree echo or other issues and you are using a third party DSP, bypass the DSP and see if the issues continue.

ZEN Technical Specifications

Operating System	
Compatible OS:	Windows 7, 8, 10 (64bit), MAC OS 10.11 & up, Linux with current CDC-ECM driver
Input	
Digital Input	M.O.S.T. 25 Fiber Optic
Output	
Digital Output:	TOSlink
Supported Digital Output:	24bit/44.1kHz
Analog Outputs:	12 Channels (RCA)
Output Voltage Peak-to-Peak:	17V
Output Voltage RMS:	6V
Analog Output Type:	Single-Ended
S/N Ratio (Analog):	114dB
Frequency Response (Analog):	18Hz - 22.05kHz
THD+N@ -1dBFS:	-94dB
DAC:	44.1kHz 32bit
DSP:	32bit Floating Point
Delay (Time Alignment):	2 time Alignments selected by Logic 7: on or o
Power Supply	
Current Consumption Standby:	<1 mA
Current Consumption Operational:	350 mA MAX
Operational Voltage:	7V -20V DC
Amp Turn-On Output:	Automatic
Amp Turn-On Voltage:	V-batt
Amp Turn-On Current Limit:	500mA
Other	
Dimensions:	4" x 5" x 1 3/8"
Weight:	10 oz
Country of Origin:	USA



**FOR TECH SUPPORT, PLEASE CALL
+(0) 44 333 700 1515**